

Valtek Control Products

Mark Six

Technical Bulletin

FCD VLATB0006 - 07

FLOWSERVE

三千控制阀网
www.cv3000.com

Valtek Mark Six Control Valves

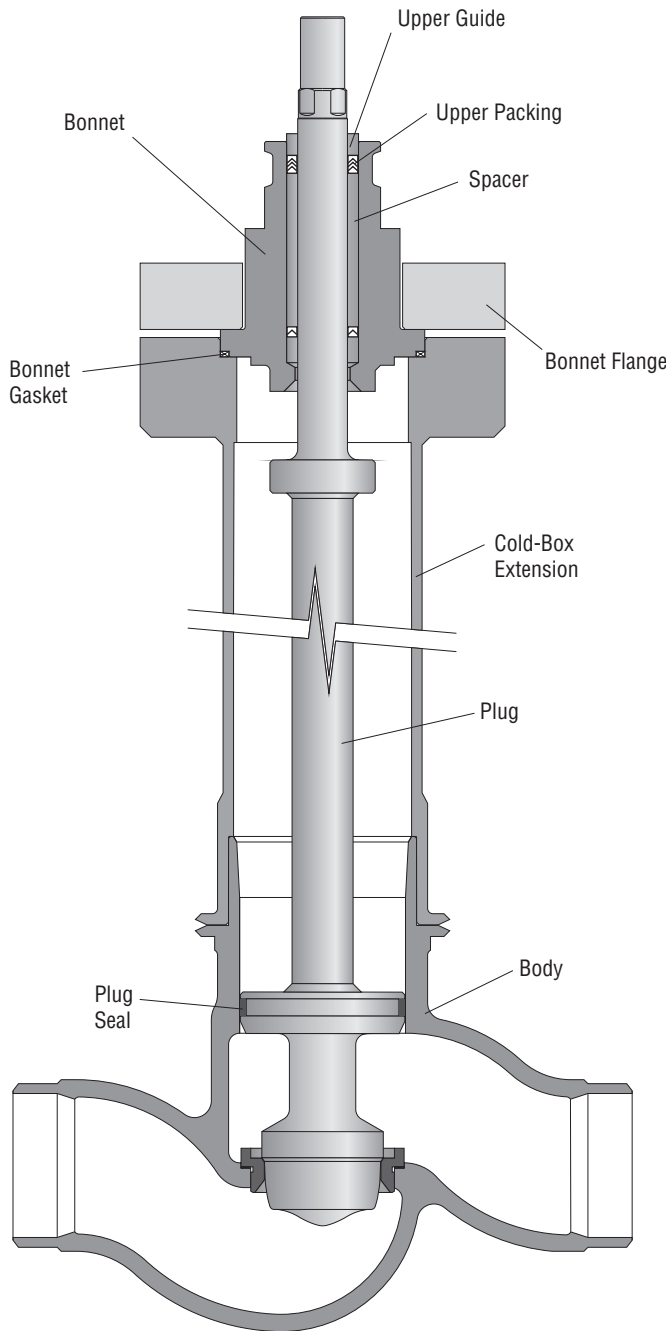

Figure 1: Mark Six Design

The Flowserve Valtek® Mark Six™ is a globe-style, single-seat, top-entry automatic control valve with a fabricated extension for cold box cryogenic applications to -425°F/-218°C. Mark Six bodies are constructed of bronze or austenitic stainless steel for high impact strength at low temperature and minimum heat transfer. Mark Six is designed for high flow capacity with a minimum of mass to reduce boil-off on valve cool-down.

The Mark Six extension design permits easy access and removal of the valve trim without breaking down the cold box. During operation, a small amount of liquefied gas passes into the extension bonnet area where it vaporizes and insulates the packing from the liquefied gas temperature. The pressure resulting from the vaporization of the liquid prevents additional liquid from passing into the bonnet area.

The Mark Six is equipped with a standard, high-performance Valtek cylinder actuator, providing high thrust for tight shutoff and exceptionally accurate control.

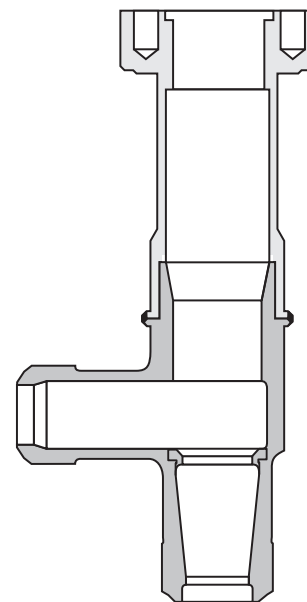

Figure 2: Angle Body Construction

Features and Specifications

Features Include:

- Streamlined, lightweight body for reduced heat transfer
- Simple bonnet seal for easy maintenance and low thermal losses
- Top-entry for easy service without breaking down cold box
- Cold box extension for packing protection and to prevent icing of the stem
- Single-seat for precise throttling and tight shutoff
- Smooth, nearly constant-area internal flow passages for high capacity and minimum turbulence
- High-thrust Mark One cylinder actuator for high performance, exceptional control and tight shutoff
- Many interchangeable parts with other standard Valtek control products



Table I: Body Specifications

Sizes	.5 through 10 inch
Forms	Globe, Angle
ANSI Ratings	150, 300 & 600
End Connections	Buttweld, all sizes
	Socketweld - .5 through 1 inch
	Integral Flange - all sizes
Bonnet Type	Standard
Bonnet Flange	Seperable
Packing	Standard, Live Loaded
Packing Configuration	Standard or Twin Seal
Trim Characteristics	Equal Percent
	Linear
	Quick Open
	CavStream
Trim Hard Facings	Alloy 6; Full Contour or Seat Surface
Soft Seat	PTFE, FEP, PCTFE
Guides	Double Top Stem Guided
Gaskets	Flat, Spiral-Wound

Table II: Standard Materials of Construction

Body	316*, 316L, 304, 304L stainless steel, bronze
Bonnet	316*, 316L, 304, 304L stainless steel, bronze
Bonnet Flange	316 stainless steel*
Bonnet Gasket	PTFE*, PCTFE
Plug	316 stainless steel, Monel, 17-5PH*, or 17-4PH/nitrided
Plug Seal	PTFE*, PCTFE or FEP/316 stainless steel
Guides	bronze*, glass-filled PTFE
Packing	PTFE Vee Ring*, Glass Filled PTFE Vee Ring
Packing Spacer	stainless steel*, bronze
Body Bolts	stainless steel*
Gland Flange	316 stainless steel*
Gland Flange Bolting	stainless steel*
Yoke Clamp	stainless steel*
Seat Ring	17-4PH*, 17-4PH / nitrided or Monel
Seat Gasket	PTFE*, PCTFE

* Standard

Trim

Plug Seals

The simple plug seal provides an effective vapor barrier between the liquefied gas and packing. A small amount of liquefied gas vaporizes when passing into the cold box extension. The pressure resulting from the vaporized liquid prevents additional liquid from entering the bonnet area.

On vented plugs, a small amount of liquid will vaporize when entering the bonnet area through a small vent hole in the plug head. In non-vented plugs, the spring-energized PTFE seal allows a small quantity of liquid into the bonnet area over a period of time. The pressure may require up to 24 hours to balance. In both cases, a PTFE sleeve guides the plug head in the polished bore of the valve body.

Since few parts are used in the seal, heat transfer to the fluid is reduced. An encapsulated bonnet gasket prevents leaks of process fluid to the atmosphere. A variety of trim combinations, including non-sparking, are available.

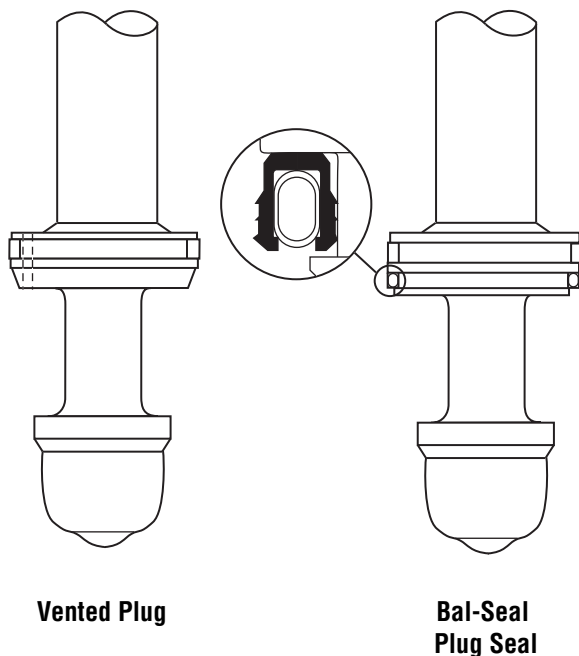

Figure 3: Mark Six Plug Designs

Soft Plugs

Bubble-tight shutoff is achieved by inserting PTFE or PCTFE onto the seating surface of the plug. Plug sizes up to 1½" use a threaded plug head design that clamps the elastomeric insert between the plug head and the plug stem. Plug sizes 2" and larger use a bolted design to retain the elastomeric insert. Self-locking inserts prevent the plug head from backing out of the plug stem and the bolts from backing out of the plug head. Leakage corresponding to this construction is Class VI. Soft plug assemblies and standard plugs are interchangeable.

Seats

Most Valtek Mark Six valves use a screwed-in seat. Flow capacity can typically be adjusted by changing the shape of the plug head. For higher flow capacities, integral seats can be machined into the body as an option.

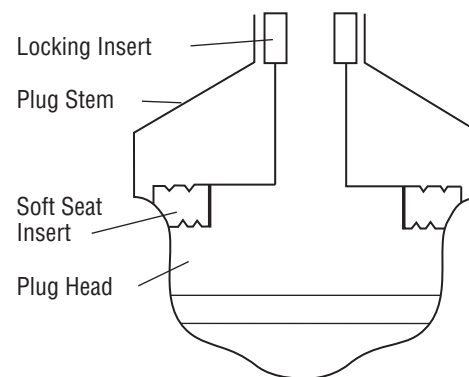

Figure 4: Threaded Plug Head

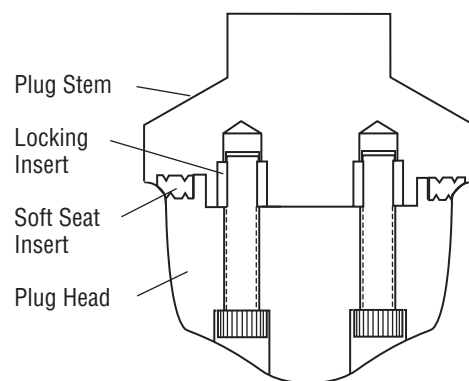

Figure 5: Bolted Plug Head

Flow Characteristics

Equal Percentage

Equal percentage characteristic is commonly used in process control. The change in flow per unit of valve stroke is directly proportional to the flow occurring just before the change is made. While the flow characteristic of the valve may be equal percentage, most control loops produce an installed characteristic which approaches linear when the overall system pressure drop is large relative to that across the valve.

Linear

Linear inherent characteristic produces equal changes in flow per unit of valve stroke regardless of plug position. Linear plugs are used on systems where the valve pressure drop is a major portion of the total system pressure drop.

Quick-Open

Quick-open plugs are used for on-off service and are primarily designed to produce maximum flow quickly.

Trim Types

Three trim types are available. Standard full area trim provides maximum C_v . Reduced trim is available in a wide variety of

sizes when lower C_v values and large bodies are required. Flow capacity is usually determined by the size of the plug head. The optional integral trim uses a seat machined into the body.

CavStream Anti-Cavitation Trim

CavStream is an anti-cavitation trim that minimizes cavitation damage by forcing cavitation bubble implosions away from metal surfaces. CavStream trim utilizes a number of small, diametrically opposed flow holes through the walls of a special plug. Flow direction for valves with CavStream trim is always over the plug. As the valve plug lifts off the seat, increasing pairs of holes are opened. Each hole emits a jet of cavitating liquid, which impinges in the center of the plug head upon the jet of liquid emitted through the opposing hole. The impinging fluid jets form a fluid cushion and an area of pressure recovery that cause the collapse of the vapor bubbles in the fluid stream away from metal parts. For further details on the workings of CavStream trim, refer to the Severe Service Equipment brochure.

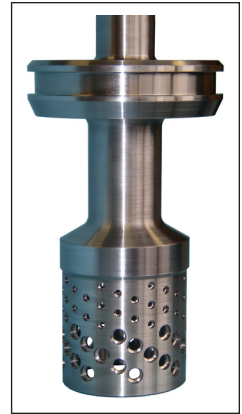

Figure 8

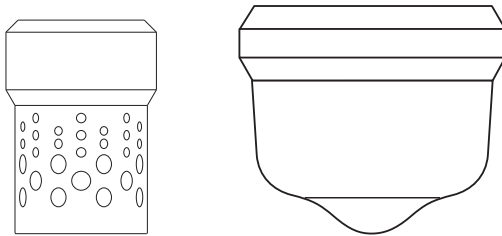

Figure 6

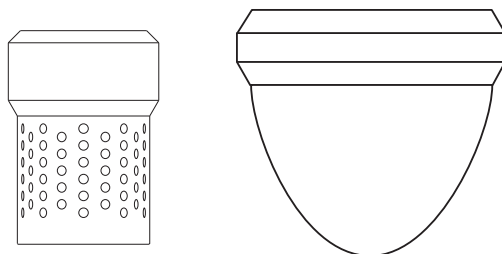
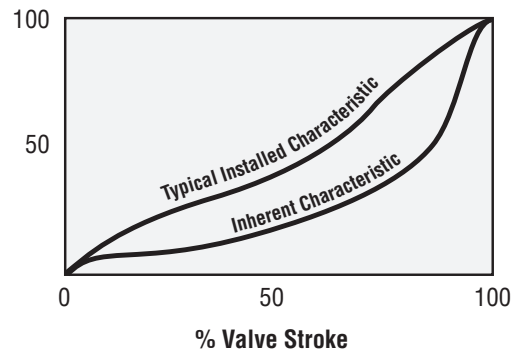
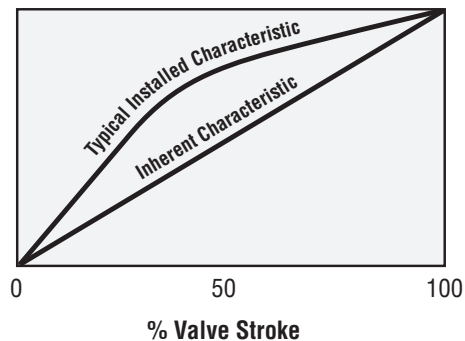

Figure 7



Standard Body Construction

The streamlined Mark Six body with fabricated bonnet extension provides maximum flow capacity while minimizing thermal losses. Both the number and weight of body components are kept at a minimum, reducing heat transfer to the fluid. One-piece body construction without gasketed joints eliminates the possibility of leaks into the cold box.

Mark Six bodies are constructed of bronze or austenitic stainless steel, both of which are face-centered cubic metals that have high yield, tensile and impact strengths at cryogenic temperatures.

Packing

Valve packing is readily accessible from outside the cold box, and the bonnet flange bolting is located such that it is accessible at or near the surface of the cold box. Standard packing is PTFE V-rings. Glass-filled PTFE and square graphite packing are optional.

Guiding

The two guides used in the packing box can be removed easily. The top guide also serves as the packing follower. Both guides are spaced widely apart, improving guiding. Glass-filled PTFE lined stainless steel or bronze guides completely eliminate guide/stem galling. Solid bronze or Alloy 6 guides are available.

Gaskets

The bonnet bottoms metal-to-metal in the body and fully retains the bonnet gasket. Bonnet gasket compression is determined by the depth of the gasket step on the bonnet which is machined to provide the compression required by the gasket. PTFE and FEP or PCTFE flat gaskets are used.

Mark Six Low Flow Control Valves

Figure 9

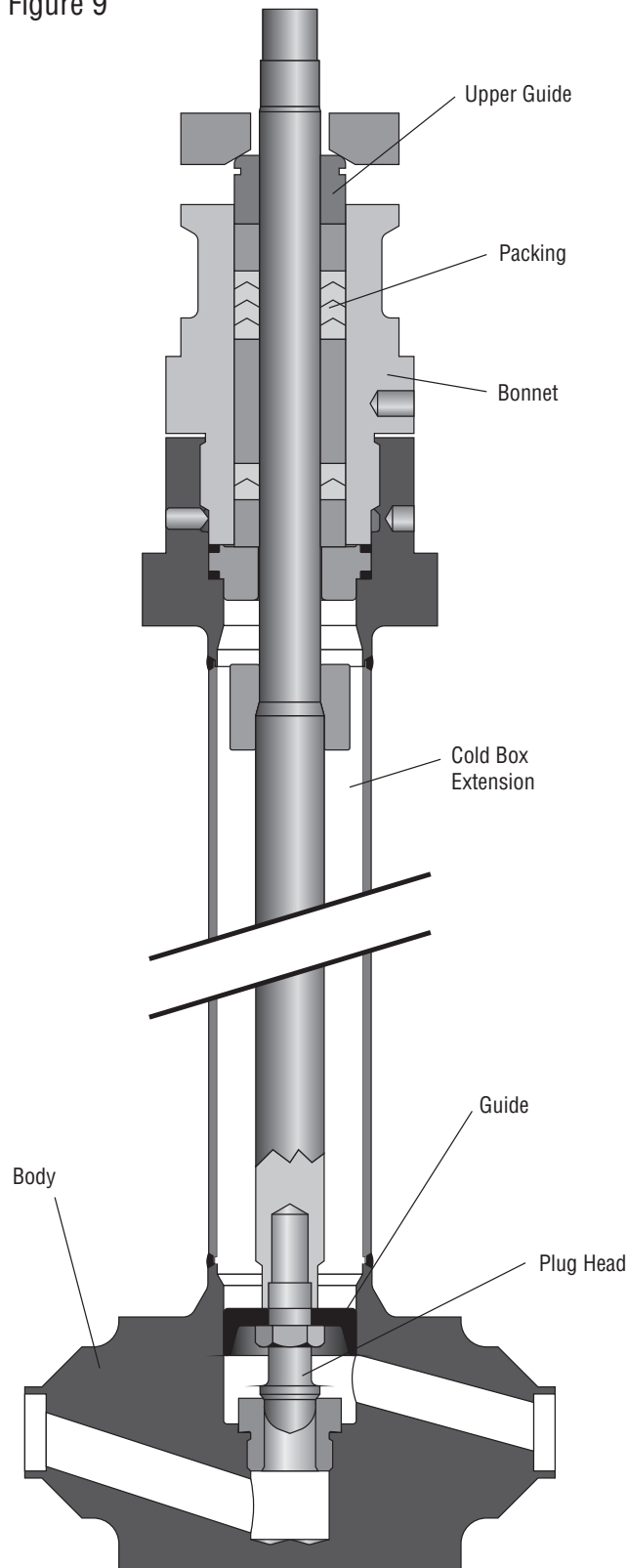

For small, precision flow in cryogenic service, the Mark Six Low Flow is the answer. Using the same principles as the standard Mark Six, the Mark Six Low Flow was redesigned to give precision control over valves with very small capacities. The smallest valve can have a maximum capacity as low as 0.012 Cv.

Table III, Low Flow Materials of Construction

Body	316L stainless steel
Bonnet	316L stainless steel, Kanigen
Gaskets	PTFE
Plug	316 stainless steel, Alloy 6
Guides	Bronze, Glass Filled PTFE
Packing Spacer	316 stainless steel
Gland Flange	316 stainless steel
Gland Flange Bolting	stainless steel
Yoke Clamp	Precision Cast stainless steel
Seat Ring	316L Kanigen, 316L Kanigen / Alloy 6

Table IV, Low Flow Body Specifications

Sizes	1/2", 3/4", 1"
Forms	Globe
ANSI Ratings	150, 300, 600
End Connections	Buttweld - all sizes
	Socketweld - all sizes
	Separable Flange - 1/2"
	Integral Flanges - all sizes
Bonnet Type	Screwed in
Packing	Standard
Packing Configurations	Standard, Twin Seal
Trim Characteristics	Equal Percentage (except 0.71)
	Linear (except 0.71)
	Quick-open (only 0.71)
Hard Facing Surfaces	Alloy 6; full-contour
Soft Seat	PCTFE (quick-open only)
Guides	Widely Spaced Stem
Gaskets	Flat

Trim Data

Table V: Trim Data

Valve Size	Trim Number	Stroke Length		Capacity C _v	
		in	mm	Equal Percent	Linear
0.75	1.00A	0.75	19	9	9
	1.00B	0.75	19	6	6
	1.00C	0.75	19	4	4
	.38A	0.75	19	2.5	2.5
	.38B	0.75	19	1.9	1.9
	.38C	0.75	19	1.5	1.5
	0.25	0.75	19	1.1	1.1
	.12A	0.50	13	0.5	0.5
	.12B	0.50	13	0.3	0.3
1	1.00A	0.75	19	15.5	15.5
	1.00B	0.75	19	12	12
	1.00C	0.75	19	9	9
	1.00D	0.75	19	6	6
	1.00E	0.75	19	4	4
	.38A	0.75	19	1.9	1.9
	.38B	0.75	19	1.5	1.5
	.38C	0.75	19	1.1	1.1
	0.25	0.75	19	1	1
	.12A	0.50	13	0.5	0.5
	.12B	0.50	13	0.3	0.3
1.5	1.5	1.00	25	35	35
	1.25A	1.00	25	31	31
	1.25B	1.00	25	15	15
	1.25C	1.00	25	12	12
	1.25D	1.00	25	6	6

Valve Size	Trim Number	Stroke Length		Capacity C _v	
		in	mm	Equal Percent	Linear
2	2	1.50	38	65	65
	1.62A	1.50	38	46	46
	1.62B	1.50	38	30	30
	1.62C	1.50	38	20	20
	1.62D	1.50	38	15	15
	1.62E	1.00	25	12	12
3	2.62A	2.00	51	116	116
	2.62B	2.00	51	80	80
	2.62C	2.00	51	60	60
	2.62D	2.00	51	30	30
4	3.50A	2.50	64	225	225
	3.50B	2.50	64	195	195
	3.50C	2.50	64	133	133
	3.50D	2.50	64	120	120
	3.50E	2.50	64	60	60
6	4.00A	3.00	76	400	400
	4.00B	3.00	76	260	260
	4.00C	3.00	76	200	200
8	7.44A	4.00	102	858	858
	7.44B	4.00	102	601	601
	7.44C	4.00	102	515	515
10	9.75A	4.00	102	1329	1329
	9.75B	4.00	102	996	996
	9.75C	4.00	102	797	797

Table VI: CavStream Trim Data

Valve Size	Trim Number	Stroke Length		Capacity C _v	
		in	mm	Equal Percent	Linear
0.5	0.75A	1	25	9	10
	0.75B	0.75	19	7	8
	0.75C	0.75	19	6	6
	0.75D	0.75	19	4	4
	0.75E	0.75	19	2.5	2.5
	0.75F	0.75	19	1.5	1.5
0.75	0.75A	1	25	9	10
	0.75B	0.75	19	7	8
	0.75C	0.75	19	6	6
	0.75D	0.75	19	4	4
	0.75E	0.75	19	2.5	2.5
	0.75F	0.75	19	1.5	1.5
1	0.75A	1	25	9	10
	0.75B	0.75	19	7	8
	0.75C	0.75	19	6	6
	0.75D	0.75	19	4	4
	0.75E	0.75	19	2.5	2.5
	0.75F	0.75	19	1.5	1.5
1.5	1.25A	0.75	19	10	10
	1.25B	0.75	19	6	6
	1.25C	0.75	19	4	4

Valve Size	Trim Number	Stroke Length		Capacity C _v	
		in	mm	Equal Percent	Linear
2	1.62A	2	51	40	46
	1.62B	1.5	38	35	35
	1.62C	1	25	24	24
	1.62D	1	25	16	16
	1.25A	0.75	19	10	10
	1.25B	0.75	19	6	6
	1.25C	0.75	19	4	4
	2.5	2	51	70	90
3	2.25A	1.5	38	46	65
	2.25B	1.5	38	44	44
	1.88A	1	25	28	28
	1.88B	1	25	16	16
	1.5	0.75	19	10	10
	3.00A	2	51	95	95
4	3.00B	2	51	65	65
	1.88A	1.5	38	44	44
	1.88B	1.5	38	28	28
6	4.75A	3	76	310	350
	4.75B	2.5	64	195	240
	4.75C	2.5	64	160	160
	3.25	2	51	110	110

Table VII: Low Flow Design Trim Data

Valve Size	Trim Number	Stroke Length		Capacity C _v	
		in	mm	Equal Percent	Linear
.5, .75, 1	0.12A	0.59	15	0.012	0.012
	0.12B	0.59	15	0.019	0.019
	0.12C	0.59	15	0.029	0.029
	0.12D	0.59	15	0.046	0.046
	0.12E	0.59	15	0.073	0.073
	0.12F	0.59	15	0.12	0.12
	0.12G	0.59	15	0.19	0.19
	0.12H	0.59	15	0.29	0.29
	0.18A	0.59	15	0.46	0.46
	0.18B	0.59	15	0.73	0.73
	0.25A	0.59	15	1.16	1.16
	0.25B	0.59	15	1.85	1.85
	0.38	0.59	15	2.89	2.89
	0.47	0.59	15	4.16	4.16
	0.71	0.59	15	6.50	6.50

Shipping Weights, Extension Lengths and Dimensions

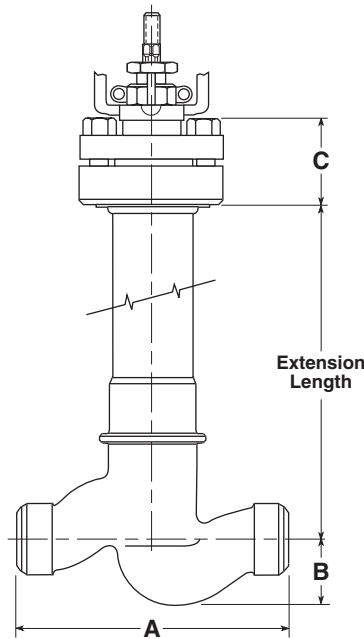
Table VIII, Bonnet Extension Length

Body Size	Standard Extension		Optional Extension					
	in	mm	in	mm	in	mm	in	mm
0.5	27	686	15	381	18	457	24	610
0.75	27	686	15	381	18	457	24	610
1	27	686	15	381	18	457	24	610
1.5	27	686	18	457	24	610	30	762
2	30	762	18	457	24	610	36	914
3	30	762	21	533	24	610	36	914
4	36	914	21	533	24	610	30	762
6	36	914	24	610	27	686	30	762
8	36	914	24	610	27	686	30	762
10	36	914	30	762	33	838	42	1067
Low Flow Design								
0.5	21	533	12	305	15	381	18	457
0.75	21	533	12	305	15	381	18	457
1	21	533	12	305	15	381	18	457

Table IX: Estimated Shipping Weight with Cylinder Actuator and Positioner

Size (inches)	ANSI Class					
	150		300		600	
	lbs	kg	lbs	kg	lbs	kg
0.5	70	32	70	32	70	32
0.75	70	32	70	32	70	32
1	70	32	70	32	70	32
1.5	85	39	85	39	85	39
2	95	43	95	43	95	43
3	190	86	200	91	210	95
4	275	125	285	129	300	136
6	400	181	610	277	640	290
8	640	290	840	381	880	399
10	1110	504	1465	665	1660	753
Low Flow Design						
0.5	36	16	36	16	36	16
0.75	36	16	36	16	36	16
1	36	16	36	16	36	16
Actuator for Oversize Cylinder Actuators (lb.)						
Original Size	Oversize	Add				
		lbs	kg			
25	50	30	14			
50	100	90	41			
100	200	125	57			

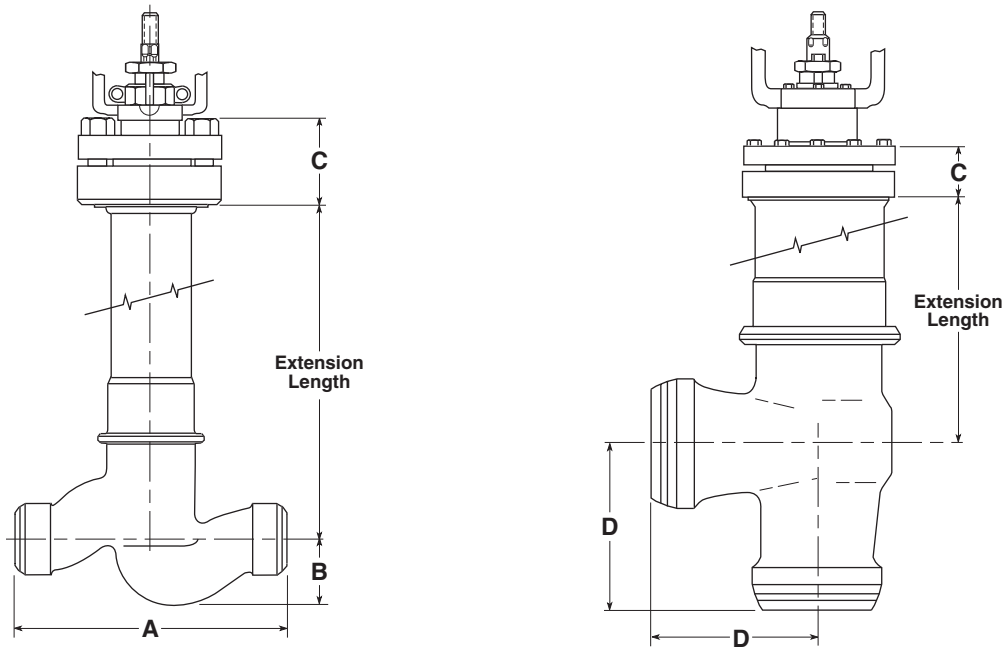

Table X: Dimensions for Class 150, 300 and 600

Body Size	Pressure Class	A ISA 75.15 Long		B		C		D		Clearance Above Actuator Required for Disassembly	
		in.	mm	in.	mm	in.	mm	in.	mm	in.	mm
0.5	150-600	8.00	203	1.775	45	3.8	97	--	--	6.8	173
0.75	150-600	8.25	210	1.75	44	3.8	97	--	--	6.8	173
1	150-600	8.25	210	1.75	44	3.8	97	4.25	108	6.8	173
1.5	150-600	9.88	251	2.31	59	3.93	100	4.75	121	8.9	226
2	150-600	11.25	286	2.25	57	4.06	103	5.75	146	9.1	231
3	150-600	13.25	337	3.39	86	5.34	136	7	178	11.3	287
4	150-600	15.5	394	5.22	133	6.06	154	8.75	222	14.1	358
6	150	20	508	5.48	139	6.04	153	8.88	226	16.1	409
6	300-600	20	508	5.75	146	8.19	208	11	279	18.2	462
8	150	24	610	7.08	180	6.94	176	13	330	20	508
8	300-600	24	610	7.48	190	8.75	222	13	330	21.8	554
10	150	29.62	752	8.44	214	7.37	187	--	--	21.4	544
10	300-600	29.62	752	8.93	227	7.37	187	--	--	21.4	544
Low Flow Design											
0.5	150-600	6.00	152	1.18	30	2.48	63	--	--	13.8	351
0.75	150-600	6.00	152	1.18	30	2.48	63	--	--	13.8	351
1	150-600	6.00	152	1.18	30	2.48	63	--	--	13.8	351

Flowserve Corporation has established industry leadership in the design and manufacture of its products. When properly selected, this Flowserve product is designed to perform its intended function safely during its useful life. However, the purchaser or user of Flowserve products should be aware that Flowserve products might be used in numerous applications under a wide variety of industrial service conditions. Although Flowserve can (and often does) provide general guidelines, it cannot provide specific data and warnings for all possible applications. The purchaser/user must therefore assume the ultimate responsibility for the proper sizing and selection, installation, operation, and maintenance of Flowserve products. The purchaser/user should read and understand the Installation Operation Maintenance (IOM) instructions included with the product, and train its employees and contractors in the safe use of Flowserve products in connection with the specific application.

While the information and specifications contained in this literature are believed to be accurate, they are supplied for informative purposes only and should not be considered certified or as a guarantee of satisfactory results by reliance thereon. Nothing contained herein is to be construed as a warranty or guarantee, express or implied, regarding any matter with respect to this product. Because Flowserve is continually improving and upgrading its product design, the specifications, dimensions and information contained herein are subject to change without notice. Should any question arise concerning these provisions, the purchaser/user should contact Flowserve Corporation at any one of its worldwide operations or offices.

FLOWSERVE CORPORATION
FLOW CONTROL
Valtek Control Products
 1350 N. Mt. Springs Prkwy.
 Springville, UT 84663
 Phone: 801 489 8611
 Facsimile: 801 489 3719
 www.flowserve.com



For more information, contact:

For more information about Flowserve Corporation, visit www.flowserve.com or call 1-800-225-6989.

Regional Headquarters

1350 N. Mt. Springs Prkwy.
 Springville, UT 84663
 Phone 801 489 8611
 Facsimile 801 489 3719

12 Tuas Avenue 20
 Republic of Singapore 638824
 Phone (65) 862 3332
 Facsimile (65) 862 4940

12, av. du Québec, B.P. 645
 91965, Courtaboeuf Cedex,
 France
 Phone (33 1) 60 92 32 51
 Facsimile (33 1) 60 92 32 99

Quick Response Centers

5114 Railroad Street
 Deer Park, TX 77536 USA
 Phone 281 479 9500
 Facsimile 281 479 8511

104 Chelsea Parkway
 Boothwyn, PA 19061 USA
 Phone 610 497 8600
 Facsimile 610 497 6680

1300 Parkway View Drive
 Pittsburgh, PA 15205 USA
 Phone 412 787 8803
 Facsimile 412 787 1944